

« « « » »

• • • • •

*ФЯГОПІ:
ПЕРВЫЕ ШАГИ МУЗЫКАНТА*

788.8 (075.3)
74.268.53 723

92

: . . ó «
« . . ó -
- . . ó . »»;

: . . ó ,
;
« . . ó «
- . . ó - »» . , .

92 : . . : : . ó
: « « » « », 2014. ó 66 .

ISBN 978-601-272-681-7

« ».
- ,
.
.

788.8 (075.3)
74.268.53 723

« ». 77 30 2014 . « « »
© « « » « », 2014

ISBN 978-601-272-681-7

	:	í í	..5
§ 1.	(-)í í	.6
§ 2.	:	-	í í í í í í í í .7
§ 3.	«	»:	í í í í í í í í í í 9
§ 4.		í í	...12
§ 5.		í í	14
§ 6.		í í í í í í í í í í	..18
§ 7.		í í	.20
§ 8.	:	,	, , í í í í í í í í í í í í .21
§ 9.		í í	.24
§ 10.		í í	...26
§ 11.		í í	28
§ 12.		í í	.29
§ 13.	.	í í í í í í í í í í í í í í	.31
§ 14.		í í	33
§ 15.		í í	.35
§ 16.	.	í í	...37
§ 17.		í í	..39
§ 18.		í í	...41
§ 19.		í í	...43
§ 20.		í í	...45
§ 21.		í í	..48
§ 22.	:		?.....49
§ 23.		í í í í í í í í í í	..50
§ 24.		í í í í	52
		í í	...60
	:	í í í í í í í í í í	..63
		í í	.65

! ,
: ,
, 'ó', !
, , , !
, , ,
, ,
.

:

ó

,

.

.



,

,

.

,

ó

,

.

,

,

,

,

ó

,

ó

,

.

.

,

,

,

.



,

.

,



«

»

.

-

.

-

,

.



«

,

».

«

».

«

,

».

,

«

»,

!

.

,

,

.

-

.

,

.

,

ó

,

.

:

.

ó

,

!

§1

(-)

, (). ,

3

, . ,

, . , . ,

. ().

, .

Wurst-Fagott, ó Cervelas.

- , - ,

, ó

, ,

» 11

. -« ó

, ,

, ó

1831

Heckel,



1.

2.

3.

4.

. 1.

? _____ !

?

U-

?

,

?

?

(1570 ó 1626).

,

,

«Bravissimo, fagotto!»

❖ Heckel,



. 3.

« »

↓

↓

↓

↓

↓

↓

↓



ó

« »



».

«

, «

».



? _____ !

- 1.
- 2.
- 3.
- 4.

?

?

?

CBET

§3

«

»:

?

ó

!

ó

!

:

1. (

S).

2.

«

»,

«

».

3.

, «

».

4.

«

».

5.

, «

» (

).

.4.

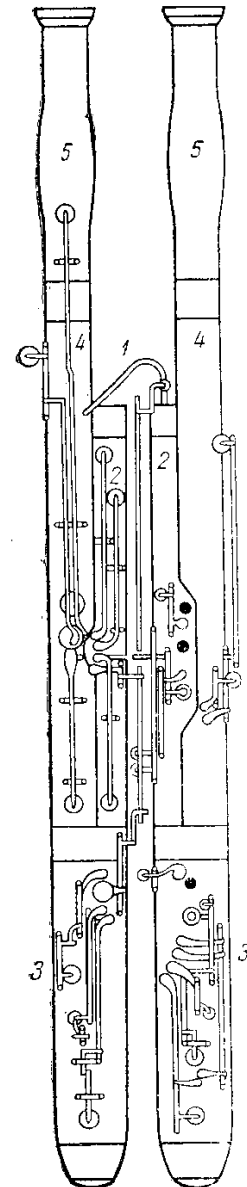



. 5.

(0)

).

(2)

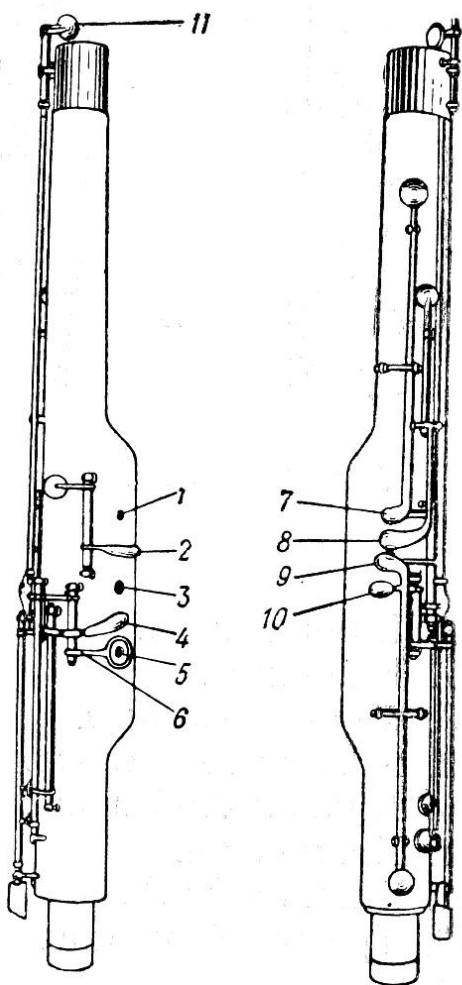

1 -

2 -

3 -

4 -

5 -

6 -

7 -

8 -

9 -

10 -

11 -

. 6.

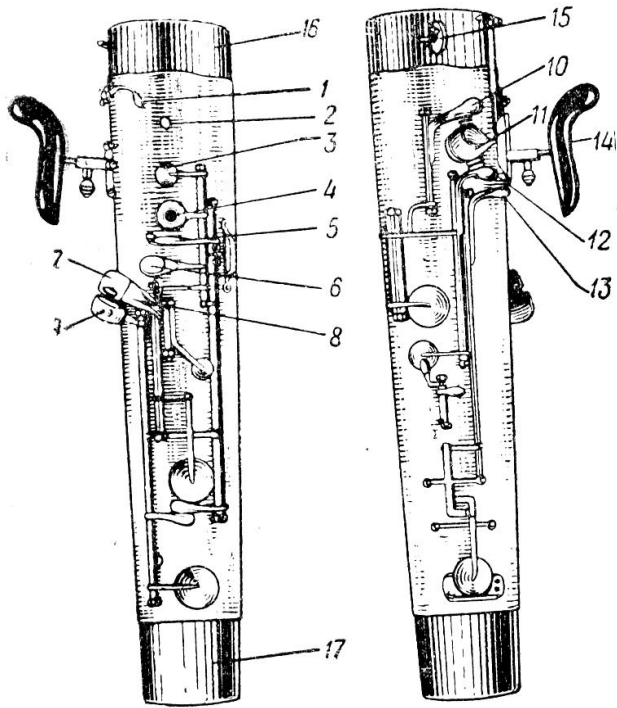

6 : -

1 - ()

2 - ,

3 - ,

4 - ,

5 - - ,

6 - ,

7 - ,

8 - - ,

9 - - ,

10 - - ,

11 -

12 -

. 7.

13 -

),

14 -

15 -

16 -

17 -

6 -

(

1 -

2 -

3 -

4 -

5 -

6 -

. 8.

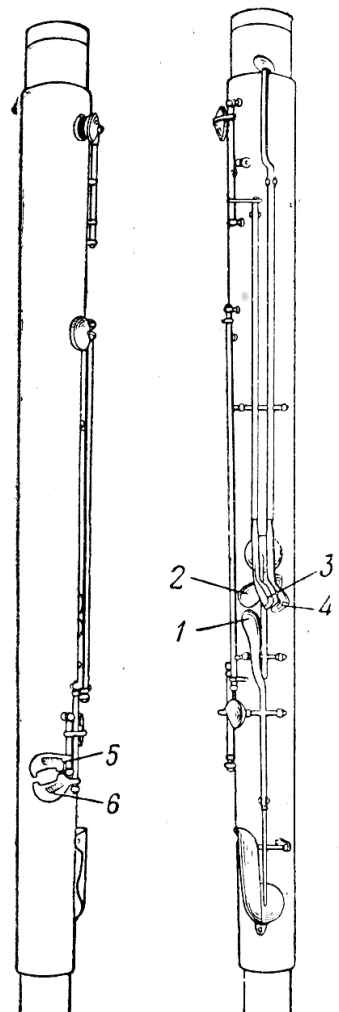

.12.

()



(.

ó),

(_____ :)

. «

,

» (. . . , 1713).

_____ :

1 -

2 -

3 -

4 -

piano

5 -

fortissimo,

6 -

staccato.

(),

piano pianissimo.

_____ ,

(_____).

_____ ó

_____ .

».

« »: _____



« _____ »,

«

»

ó





0,5 ó 1 ,

? _____ !

- 1.
- 2.
- 3.
- 4.

?

?

?

?

§5

ó

!

!



XVIII

XVI

õcon fagottoö.



XVIII

✧ _____ 38

?



XVIII

✧ _____)

(

✧ _____

B-dur.

».
(, , ,) *Es-dur.*

✧ _____.

« »».



XIX

✧ _____.

5.

« 3».

C-dur. « »

✧ _____.

ó

ó

« ».

✧ _____.

« »

« - ».

« »
().

:
« « » , -
()

✧ _____ « »
« » ,

✧ _____ « »
« »

⌚ XX

✧ _____ « »
« » ,
✧ _____ « » Ó

✧ _____
✧ _____ « » , ,

✧ _____ ,
« » ()
« » ,
« » ,

« »
✧ _____ « » ,

◇ _____

()

田 1.

2.

§6

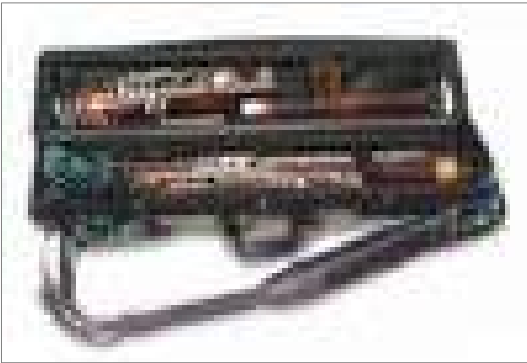

. 13.

?

- 1.
- 2.
- 3.
- 4.
- 5.
- 6.
- 7.
- 8.

?

1 -

❖

❖

➤

➤

❖

2 -

❖

❖

3 - «

ó

»

❖

_____:

ó 1

❖

_____:

ó 2 ó 3

❖

2 ó 3

➤

❖

4 -

❖

❖

❖

➤

➤



5-



6-

1.

2.

? !
?

?

§7

ó

ó

,

ó

,

!

СНОРК



()

()

↓

↓

РАБОТА

↑↑
↑↑
↑↑

↑↑

↑↑

↑↑

§8

staccato.

ó

ó

ó

í

ó

(

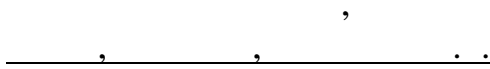

?

«

».

«

»

:

« ó
ó

».

« »,

.

«

»

,

,

,

,

.



,

,

.



,

,



_____.

_____,

_____.

(

:

-

,

);

-

,



,

-

_____ « _____ »,

« _____ »

.

.



:

,



,

;



.



.



,



.



.

.



,

(

).



,

(

!).



:

()

ó

,

!



ó





,

,

«

»

!



!).

(

ó

ó



,

«

,

».

ó

(

!).



«

»

ó

,

«

»

!



ó

!

ó

«

- , - ,

», - . .
ó , !



!

ó



« »| , \!

:

« »!

1.

, ,

2.

, .

§9

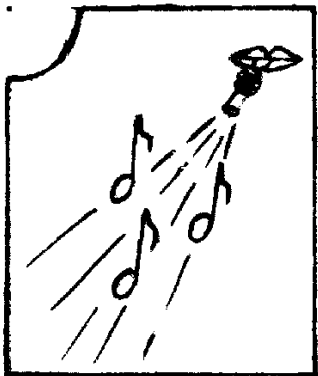

.emboucher ó

. 14.

,).

- ,
_____ (

« »;

-

,

,

,

_____ ,

,

(

).

,

_____ , - ,

_____ .

) () ()

(_____)!

1-

2-

3-

4-

○ (:)

○ ;

○

○ ,

○

..

« »



ó « », ó !



ó !



!



« _____ , _____ »
ó



:
ó 1 ó 2 . -



, ?



(), (()
).)
).



, ó
 :
 « »!



(
) ó :

- _____
 _____.
 - _____
 _____.
 - _____ (_____),
 _____.
- ? _____ !

- 1.
- 2.
- 3.

?

?

§10

ó

?

/	500 ³ . : = 4 : 5 -	ó 3500 ³ - . 1 : 20 800

?

-
-

? _____ !

?

?

?

- 1.
- 2.
- 3.

§11

ó , . :
 , , !
 , , .

, , ,
 , , ,

- , .
 , , ! ,
 , , .

« »



! , , ,
 .



, , , , ,
 , .



« ».



, .
 , , ,
 : .



!
 ,



!
 !
 !

(

).

6.

7.

8.

9.

10.

11.

12.

13.

14.

15.

16.

17.

18.

19.

20.

21.
22.

23.
24.

§13

_____ ó
 _____ :
 _____ :

_____ ?



 ➤
 ➤

-
-
-



▪

- 1.
- 2.
- 3.

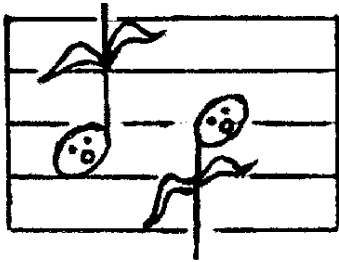

. 16.

(§§ 9, 10, 11).



-
-
-
-

ó
 .
 ?
 ?
 ?
 §14

ó
 .
 ó
 .
 ,
 ,
 ,
 .
 ó

« » _____
 (, , ,
 ó
 ,
 ó
 ,
 .

ó
 ,
 ,
 .
 ,
 ,
 .
 ,
 ,
 .

ó
 ,
 ,
 .
 ,
 .
 .
 .

§ 15

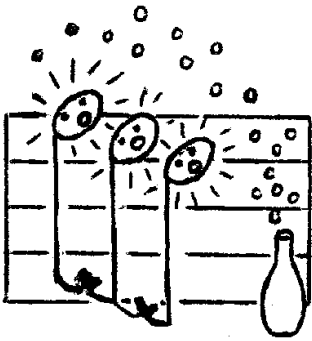

_____ ó

_____ ó

. 17. « »

« »

_____ :

•

•

■

■

■

○

○

○

○

○

■

(, ,)

1. _____

2. _____

3. _____

4. _____

5. _____

6. _____

(_____ « _____ » _____),
(_____)



?

« _____ »



!



ó



? ó



_____ ó ;

-
-
-
-
-

- 1.
- 2.
- 3.
- 4.
- 5.

? _____ !

§ 16

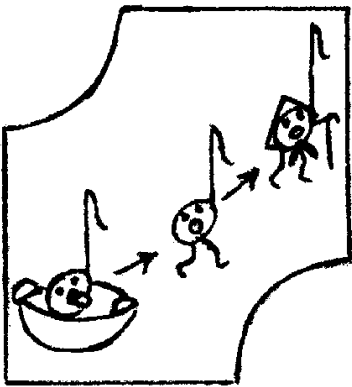

_____ - 1)

, 2)

. 18.

ó

? _____ !

- 1. ?
- 2. ?
- 3. ?
- 4. ?

§ 17

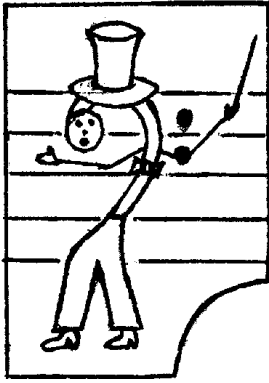

_____ ó 1) (, ,), 2)
 (-
).
 . 19.

1. , : (legato).

2. , , non legato.

- o ó détaché, marcato, portato, non legato.
- o ó staccato, staccatissimo, staccato, martelé.

3. (, , legato staccato).

4. (portamento, frullato).

détaché (. « , »).

- , .
 - ó .
 - .
 - ó .
- « »

↑ , , non legato!

↑ , détaché.

marcato (. « ») marcato.

▪ , .
▪ , ; .
▪ « »
☞ *marcato* ,

☞ , *marcato.*
legato (. « »)
legato. ,

▪ .
▪ , . ó
▪ .
▪ .
▪ , .
▪ .
▪ « »

☞ , *legato?* ,
« » .
☞ ó « ».

☞ .
☞ *legato* .
legato . ó

☞ , *legato.*
staccato (. « »)
staccato (stacc.).

▪ , .
▪ , .
▪ .



○

forte

○

piano



!

«

»

ó



!



!



!

_____ ó

(

_____ ó)

•

;

•

•

staccato.

? _____ !

1.

?

2.

?

3.

?

§ 19

_____ *ó*

Diminuendo ↓ fortissimo (ff, fffí)
 ↓ forte (f) ↑
 ↓ mezzo forte (mf) ↑
 ↓ mezzo piano (mp) ↑
 ↓ piano (p) ↑
 ↓ pianissimo (pp, pppí) ↑ crescendo

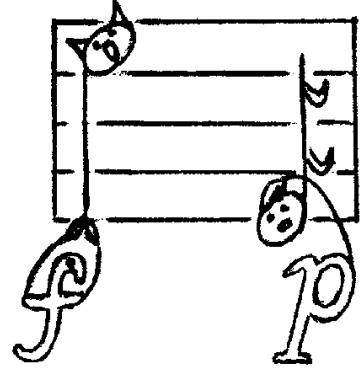

. 20. «Forte» «piano»

mezzo forte mezzo piano

ó

ó

ó

piano *ó* « » ! diminuendo

○ , ,
 ▼ () ,
 ○ ó , ó .
 ▼ ()
 ▼).
 ▼ .

☞ ó , « »
 !

☞ *mezzo forte*
 !

☞ ,

☞ *forte piano* ,

☞ *forte* ,

☞ *forte* ,
piano , , ,

: - « »!

☞ ,
 « - »!

☞ , .

1. ? !
2. ?
3. ?
4. *forte* *piano*?

, , , , , ,
 ()
).

§ 20

_____ (. vibrato, . « ») ó (. 5 7)

ó

_____?

•

•

•

•

_____?

ó

)

(

,

(

).

ó

•

•

•

:

•

,

,

•

.

.

,

,

,

.

,

,

.

:

•

,

,

.

•

-

,

-

.

:

•

-

,

.

•

,

.

.

.

,

,

.

()

.

,

(,).

,

.

,

.

:

•

.

•

,

.

_____?

✓ _____,

✓ _____?

« »

✓ _____:

1.

2.

■

3.

■

4.

5.

6.

■

7.



- 1.
- 2.
- 3.

? _____ !

?

?

?

§ 21

_____ ó 1)

, | , , , , . b;

2)



. 21.

« ».

« »

-
-
-
-

ó

x

:

○

○

○

○

○

x

(30
)

30
ó

2 6 3

x

«

,
» -

!

? _____ !

1.

?

2.

?

3.

?

4.

?

§ 24

-

Не спеша

1 $\text{bass clef } 4/4$ $\text{quarter notes: } G_2, A_2, B_2, C_3, D_3, E_3, F_3, G_3, A_3, B_3, C_4, D_4, E_4, F_4, G_4, A_4, B_4, C_5$

2 $\text{bass clef } 4/4$ $\text{quarter notes: } G_2, A_2, B_2, C_3, D_3, E_3, F_3, G_3, A_3, B_3, C_4, D_4, E_4, F_4, G_4, A_4, B_4, C_5$

3 $\text{bass clef } 4/4$ $\text{quarter notes: } G_2, A_2, B_2, C_3, D_3, E_3, F_3, G_3, A_3, B_3, C_4, D_4, E_4, F_4, G_4, A_4, B_4, C_5$

4 $\text{bass clef } 4/4$ $\text{quarter notes: } G_2, A_2, B_2, C_3, D_3, E_3, F_3, G_3, A_3, B_3, C_4, D_4, E_4, F_4, G_4, A_4, B_4, C_5$

5 $\text{bass clef } 4/4$ $\text{quarter notes: } G_2, A_2, B_2, C_3, D_3, E_3, F_3, G_3, A_3, B_3, C_4, D_4, E_4, F_4, G_4, A_4, B_4, C_5$

6 $\text{bass clef } 4/4$ $\text{quarter notes: } G_2, A_2, B_2, C_3, D_3, E_3, F_3, G_3, A_3, B_3, C_4, D_4, E_4, F_4, G_4, A_4, B_4, C_5$

7 $\text{bass clef } 4/4$ $\text{quarter notes: } G_2, A_2, B_2, C_3, D_3, E_3, F_3, G_3, A_3, B_3, C_4, D_4, E_4, F_4, G_4, A_4, B_4, C_5$

8 $\text{bass clef } 2/4$ $\text{quarter notes: } G_2, A_2, B_2, C_3, D_3, E_3, F_3, G_3, A_3, B_3, C_4, D_4, E_4, F_4, G_4, A_4, B_4, C_5$

9 $\text{bass clef } 2/4$ $\text{quarter notes: } G_2, A_2, B_2, C_3, D_3, E_3, F_3, G_3, A_3, B_3, C_4, D_4, E_4, F_4, G_4, A_4, B_4, C_5$

10 $\text{bass clef } 2/4$ $\text{quarter notes: } G_2, A_2, B_2, C_3, D_3, E_3, F_3, G_3, A_3, B_3, C_4, D_4, E_4, F_4, G_4, A_4, B_4, C_5$

TENUTO

11

12

13

14

15

16

17 Не спеша *V*

18 *V*

19 Не спеша *V*

20 Медленно *V*

21 Оживленно

22

23 Весело *f* *mf* *V*

24 Медленно *mf*

25 Подвижно *mf* *V*

26 Умеренно скоро *f* *p* *V*

mf *p* *V*

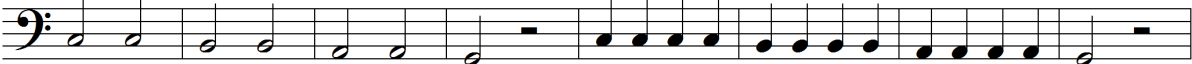
27  Musical staff 1 of system 27, bass clef, containing a sequence of eighth and quarter notes.

 Musical staff 2 of system 27, bass clef, containing a sequence of quarter and eighth notes.

 Musical staff 3 of system 27, bass clef, containing a sequence of quarter and eighth notes.

 Musical staff 4 of system 27, bass clef, containing a sequence of quarter and eighth notes.

28  Musical staff 1 of system 28, bass clef, containing a sequence of quarter and eighth notes.

 Musical staff 2 of system 28, bass clef, containing a sequence of quarter and eighth notes.

29  Musical staff 1 of system 29, bass clef, containing a sequence of quarter and eighth notes.

 Musical staff 2 of system 29, bass clef, containing a sequence of quarter and eighth notes.

30  Musical staff 1 of system 30, bass clef, containing a sequence of quarter and eighth notes.

 Musical staff 2 of system 30, bass clef, containing a sequence of quarter and eighth notes.

31  Musical staff 1 of system 31, bass clef, containing a sequence of eighth notes with triplets.

 Musical staff 2 of system 31, bass clef, containing a sequence of eighth notes with triplets.

 Musical staff 3 of system 31, bass clef, containing a sequence of eighth notes with triplets.

40

Two staves of musical notation in bass clef, 6/8 time signature. The first staff contains measures 40 and 41. The second staff contains measures 40 and 41. The music features eighth and sixteenth notes with various rests and ties.

LEGATO

41

Adagio

Two staves of musical notation in bass clef, 3/4 time signature. The first staff contains measures 41 and 42. The second staff contains measures 41 and 42. The music is marked 'Adagio' and features half notes and quarter notes with ties.

42

Two staves of musical notation in bass clef, 2/4 time signature. The first staff contains measures 42 and 43. The second staff contains measures 42 and 43. The music features eighth and sixteenth notes with ties.

43

Two staves of musical notation in bass clef, common time (C). The first staff contains measures 43 and 44. The second staff contains measures 43 and 44. The music features quarter and eighth notes with ties.

44

Two staves of musical notation in bass clef, 6/8 time signature. The first staff contains measures 44 and 45. The second staff contains measures 44 and 45. The music features eighth and sixteenth notes with ties.

45

Two staves of musical notation in bass clef, 9/8 time signature. The first staff contains measures 45 and 46. The second staff contains measures 45 and 46. The music features eighth and sixteenth notes with ties.

46

Two staves of musical notation in bass clef, 9/8 time signature. The first staff contains measures 46 and 47. The second staff contains measures 46 and 47. The music features eighth and sixteenth notes with ties.

47

48

49

STACCATO

Allegro moderato

50

Allegretto

51

Musical notation for measures 51-52, Allegretto tempo. Two staves of music in 2/4 time, featuring eighth and sixteenth notes with various articulations.

Andante

52

Musical notation for measures 52-53, Andante tempo. Two staves of music in 2/4 time, featuring quarter and eighth notes with a slower pace.

Moderato

53

Musical notation for measures 53-54, Moderato tempo. Three staves of music in 3/4 time, featuring eighth and sixteenth notes with accents and slurs.

Andante con moto

54

Musical notation for measures 54-55, Andante con moto tempo. Three staves of music in common time, featuring eighth notes, triplets, and a "simile" marking.

:

?

?

ó

ó

CLASSIK

«

»

ó

!

ó

ó

ó

!

ó

- ✓
- ✓
- ✓
- ✓
- ✓

?

ó

!

!

!

« - » ().
, « », « »,
, ,
, ,
, « », ()
, , ,
, - ; -
, . (. . .)
, ()
, : - -
, (,) ...
« , , ó !» -
,
.

« , , !» -
. ó
,
!»
« ! , !
ó .
!» -
.

